

StarFish Sidescan Sonar  
**Hull-Mounted System Manual**



# Contents

1. Introduction .....	3
2. Getting Started .....	4
2.1. What Your System Contains .....	4
2.2. Quick Start .....	4
3. Setting Up The System .....	5
3.1. Choosing A Power Supply .....	5
3.2. DC Power .....	5
3.3. AC (Mains) Power .....	5
3.4. Connecting The Components .....	6
3.5. Choosing A Mounting Location .....	7
3.6. Mounting The Sonar Transducer .....	9
4. Operating the Sonar .....	10
5. Understanding Sidescan Imagery .....	11
5.1. What Is A Side-Scan Sonar? .....	11
5.2. What Does A Side-Scan Sonar Image Look Like? .....	12
5.3. Calculating Depth Below The Sonar (Altitude) .....	12
5.4. Calculating The Distance To A Target .....	13
5.5. Acoustic Shadows .....	13
5.6. Reflected Target Intensity .....	14
5.7. Example Side-Scan Sonar Images .....	15
5.8. Gain & Contrast Settings .....	16
5.9. Shallow Water & Channels .....	16
5.10. Tips For Good Imagery .....	17
6. Safety .....	18
6.1. Electrical Safety .....	18
6.2. Operational Safety .....	18
6.3. Other Precautions .....	18
7. Care Of Your Starfish .....	19
7.1. Operational Care .....	19
7.2. Maintenance & Cleaning .....	19
7.3. Storage .....	19
8. Troubleshooting .....	20
9. Product Support .....	21
10. Limited Warranty Policy .....	22
11. Notices .....	23
12. Specifications .....	24
13. Index .....	27

## 1. Introduction

Thank you for purchasing your hull-mounted StarFish Seabed Imaging System, a revolutionary high definition hull-mounted side-scan sonar system which produces near photographic quality sonar images of the seabed.

Whether surveying lakes, rivers or the open ocean for dive sites, submerged structures, shipwrecks or research purposes, StarFish gives you the capability to capture detailed images of the seabed for work or play, making hi-tech seabed imaging accessible to anyone. With StarFish the seabed is your playground...

Simply fix the StarFish side-scan sonar transducer to the hull of a vessel, large or small, to capture real-time digital images of the seafloor below. StarFish is truly 'Plug and Play' connecting to any Microsoft® Windows® based PC or laptop via a USB connection.

The simple intuitive StarFish “Scanline” software makes seabed imaging extremely easy for novices and experienced side scan sonar users alike.

Before proceeding, we recommend that you read the safety, installation and operation guidelines in this user guide, in order to get full benefit from the features of the StarFish system.

We hope you get many years of trouble free use from your StarFish sonar. However, should you have any difficulties please refer to the “Product Support” section at the end of this manual for details on how to obtain technical support, upgrades and repairs.

### Safety

Before installing and using this product, please read through the “Safety” section at the rear of this manual.

Throughout the documentation the following symbols are used to indicate special precautions or procedures:



#### **WARNING!**

This symbol indicates a warning you should follow to avoid bodily injury or damage to your equipment.



#### **CAUTION**

This symbol denotes precautions and procedures you should follow to avoid damage to your equipment.



#### **NOTE**

This symbol denotes special instructions or tips that should help you get the best performance from your system.

## 2. Getting Started



### 2.1. What Your System Contains

Before proceeding, please check that your StarFish system box contains the following items...

- StarFish hull-mount sonar transducer head (with supplied cable).
- StarFish transducer hull mounting bracket.
- StarFish sonar top-box electronics module.
- AC to DC universal power adapter (and international plug adaptors).
- DC power lead – cigar plug (fused) to 2.1mm plug.
- DC power lead – cigar socket to crocodile clips.
- USB 2.0 Cable (type-A to type-B connectors).
- StarFish “Scanline” software and drivers USB Drive.
- User Guides.
- Bag of tools & sundries
  - 5 × M6×25mm stainless steel button-head screws,
  - 1 × 4mm Allen key

You will also need...

- Microsoft Windows 7/8/10 compatible computer (or laptop), with 1 free USB port (minimum).
- Battery (for DC operation) or suitably protected AC mains outlet (see page 5).

Additionally, you may also require...

- 10mm spanner for adjusting the angle transducer on the hull mounting bracket.
- Suitable fasteners to attach the mounting bracket to the hull of your vessel.
- Clips to secure the transducer cable to the hull of your vessel.

### 2.2. Quick Start

To get started straight away, you can use the accompanying “Quick Start” guide to get up-and-scanning, or read on for further detailed operational instructions and tips.

For further details on installing and operating the “Scanline” software package, please refer to the “StarFish Scanline Software User Guide” booklet.



**Note: Do not connect the sonar USB electronics to the PC until the “Scanline” software and drivers have been installed – this will simplify the installation procedure.**

## 3. Setting Up The System

### 3.1. Choosing A Power Supply

Before setting up your StarFish system, you first need to decide on the power source you will use – either...

- A DC supply (such as a battery or boat electrical system), or
- Mains from the universal AC-DC adapter included with the system.



**While the StarFish has internal voltage and current protection circuitry, any DC supply you use should be externally fused with a quick blow fuse rated at 1A.**



For best performance of the StarFish, you should ensure any power source is “clean”, meaning it is free from electrical noise possibly caused by mains-inverters, electrical motors or any other similar “high-current switching” devices.

Additionally, for DC supplies, the source should be a fully regulated and smoothed power source – a dedicated battery is ideal for this.

### 3.2. DC Power

In marine conditions, where there is a high chance of equipment getting wet, the use of a low-voltage DC power supply is always recommended.

The StarFish electronics module has a 2.1mm DC input socket that will accept voltages between 9V and 28V, and will require a supply capable of delivering 5W. Typically this means the StarFish will require just under 500mA at 12V, or just under 250mA at 24V.

As DC supplies come in many varieties, several adaptor cables have been included with your StarFish.

- Use the “Cigar-Plug to 2.1mm cable” to connect your StarFish to either a 12V or 24V system. The plug itself can be disassembled to access the fuse inside it.
- Use the “Crocodile-clips to Cigar-Socket” adapter cable, for connecting to battery terminals, or other similar power sources.



If you are making your own wiring loom for the StarFish, you should ensure that the centre pin of the StarFish power connector is the positive DC voltage, and the outer connection of the plug is ground (or negative).

### 3.3. AC (Mains) Power

The AC power adapter is included for situations where the electronics will be used in a protected and dry environment (such as a boat wheel-house), and where a suitably fused and protected mains supply is available.

- The AC adaptor will accept voltage in the range of 100V to 240V AC, and 47Hz to 63Hz.
- Four universal adaptor plates are supplied with the power supply, allowing it to be used in most countries.



**When using the AC (mains) power supply, remember that electricity and water do not mix.**

**To avoid electrical shock, you should only use the AC supply in a dry and enclosed environment, such as a cabin on board a boat.**

**Ensure the supply has suitable protection such as quick-trip circuit breakers and an RCD.**

**Only handle the StarFish equipment with dry hands.**

### 3.4. Connecting The Components

Having chosen your power source, the next step is to connect the components of the StarFish system.



If this is the first time you're using the StarFish system, it is recommended you install the "Scanline" software and USB hardware drivers on your laptop/PC before connecting the electronics module to it. Refer to the accompanying "Scanline User Guide" for details on how to do this.

Once the "Scanline" software and drivers are installed, make the following connections...



If possible, turn off the power supply – if this is not possible, make the power connection last.

1. Connect the StarFish sonar transducer head to the "top box" electronics module, with the 6-way round connector.

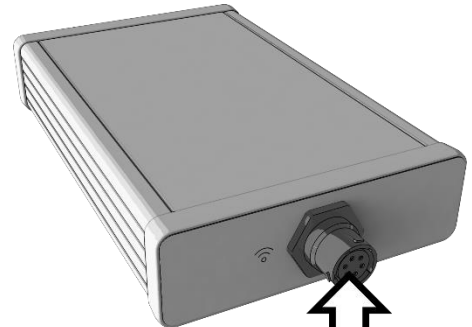

Sonar Transducer Connector

2. Connect the electronics module to a USB port on the laptop/PC using the supplied USB lead (type-A connector to type-B).
3. Connect DC power to the electronics module with the 2.1mm power jack – this may be from a DC source, or the included AC-DC adapter. Follow the selection and safety guidelines in the "Choosing A Power Supply" section above.

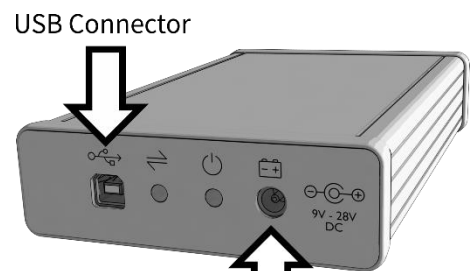

DC Power Connector

4. Finally, once you are happy with the connections, turn on the power.

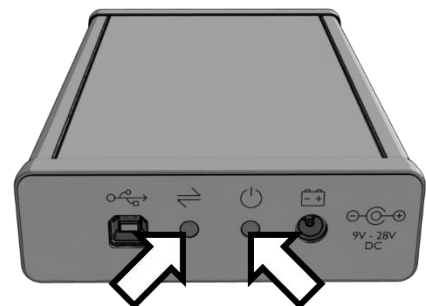

Activity Indicator

Power/Status Indicator



When powered up, the "Power/Status Indicator" will illuminate and flash – indicating that the Topside box is ready for use.

When the sonar is 'pinging' (transmitting and receiving), the "Activity Indicator" will flash.

### 3.5. Choosing A Mounting Location

Before you can start using the hull-mounted Starfish Sonar system in the field, you will need to mount the sonar transducer to the hull of your boat. Correct mounting of the sonar is essential in order to achieve the best image results, and as each hull is different you should consider the following points when deciding on a suitable mounting location...

#### Avoid creating acoustic shadows

The hull mounted StarFish transducer has transmitter and receiver elements located on either side of the moulding that are angled 30° down from the horizontal, and acoustically transmit sound in a “fan beam” of narrow width (refer to the specification of your StarFish product for the exact width), but wide vertically, with most of the acoustic energy confined to the centre 60° of the beam.

The arrangement allows the StarFish to perform well in shallow water at long ranges, and see almost directly below it, but incorrect placement on the hull could cause “acoustic shadows” or “reflections” to be produced from the hull, keel or rudder.

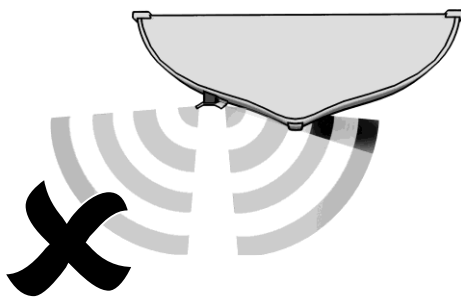

*In this position, mounted directly on the hull, the keel is casting a shadow on the starboard channel*

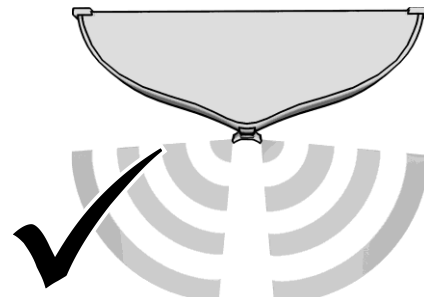

*In this position, mounted on the keel, no other parts of the hull are obstructing the acoustic beams.*



Acoustic shadows will create blind spots in the sonar’s field of vision and may reduce its maximum working range. Reflections from the hull may create a ‘ghost’ or mirror image of the opposite channel on the sonar display.

#### Reduce vulnerability to grounding

When mounting the sonar on your vessel, make sure there is always a point on the hull that is lower than the transducers location. This will reduce the risk of damage to the transducer should you run aground or collide with any submerged obstacle.

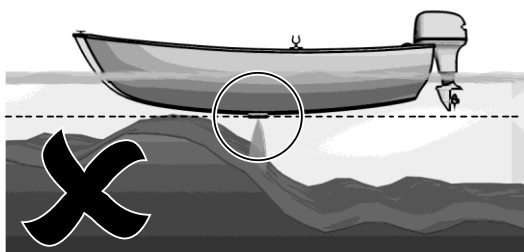

*In this position, the transducer is vulnerable to submerged hazards*

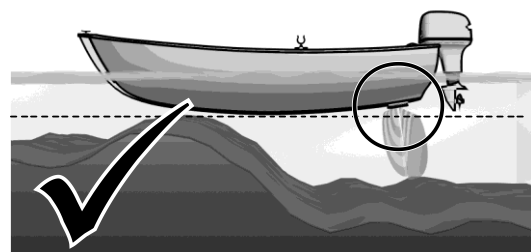

*Above, the keel at the centre of the boat is lower than at the stern, and offers protection to the transducer.*

#### Position in relation to the vessels propeller

Ideally the StarFish transducer should be mounted to the vessels hull in front of the vessels propeller, as this introduces small air-bubbles into the water which in-turn act as reflectors of sound and degrade the range and quality of the sonar imagery.

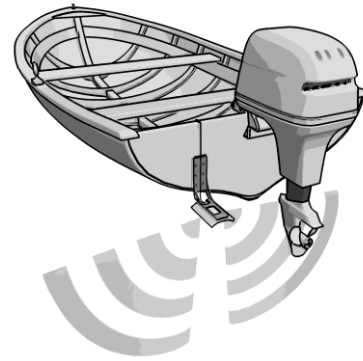
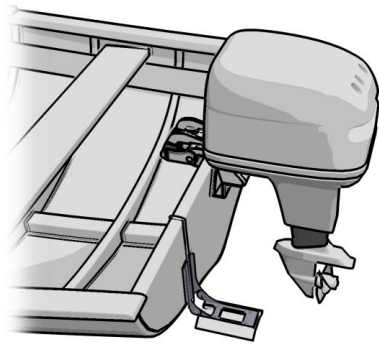

**If using an outboard motor to propel and steer your boat, ensure that the propeller does not touch the transducer when the steering is at its extremities.**



Try and keep a minimum distance of 400mm between the transducer and propeller to minimise mechanical interference (noise).



If it is not possible to mount the transducer in front of the propeller, efforts should instead be made to mount the transducer lower than it, such that its turbulence does not obstruct the acoustic beams.

#### Avoid cavitation & turbulence

When mounting the transducer onto the hull of your boat, it is important that a location is chosen that under normal conditions is known to be free from turbulence and aeration. You should also ensure the transducer is angled such that cavitation and turbulence is minimised on the transmitter and receiver surfaces as this may distort or degrade the sonar imagery. The figures below illustrate this principle...



*Transducer is angled up.*



*Transducer is level.*

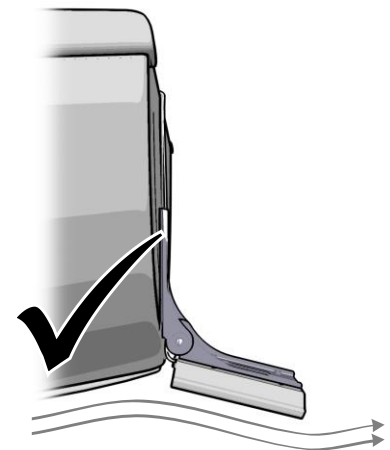

*Transducer is angled slightly down.*



Avoid mounting the transducer behind features on the hull of your vessel (such as rivets, strakes or steps) that may introduce cavitation or turbulence into the water.



### 3.6. Mounting The Sonar Transducer

You may choose to mount the sonar transducer directly to the hull or keel of your boat (following the recommendations discussed previously), although where possible we would recommend the use of the additional mounting bracket and the following procedure...

1. Secure the top part of the bracket to a flat surface on the hull or keel of your boat, using screws, bolts or other fixings depending on its construction.
2. Pass the transducer cable through the hole between the two halves of the mounting bracket. Ensure you have enough slack cable to allow the bracket to pivot freely without the cable becoming taut.
3. Using a 10mm spanner, tighten the bolts on the hinge of the bracket to fix the mounting angle of the transducer.
4. Using the 4mm Allen key included, secure the black moulded transducer assembly to the underside of the mounting bracket. The label on the transducer indicates the front (and hence port and starboard channels).
5. Use small cable clips to secure the remainder of cable to the hull of the boat and prevent it fouling on any other equipment.

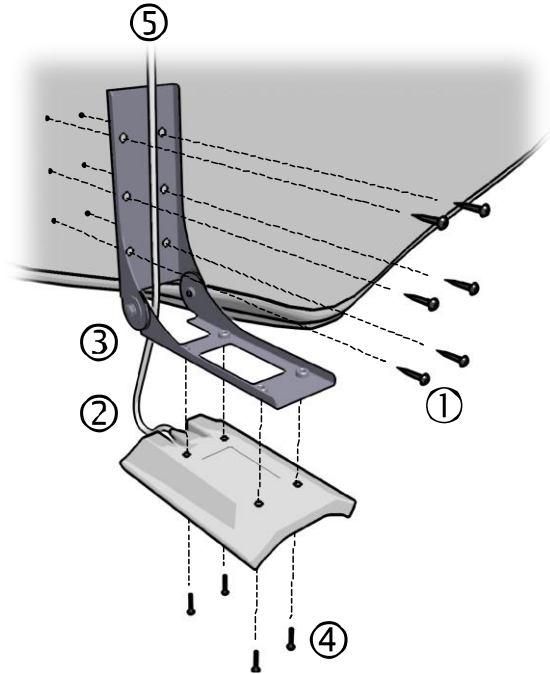

**When attaching the sonar transducer, mounting bracket or cable to the boat, choose a suitable location and fixing such that the watertight nature of the hull is not compromised! If in doubt, please contact the manufacturer of your vessel.**



The cable length on the transducer may be increased up to a maximum of 20 metres using a “twin, screened, twisted pair” cable. Contact StarFish technical support for details of available extension cables.



When routing the transducer cable...

- Try to avoid running it parallel and in close proximity to other high-current cables, radio antenna cables or anything else that may be a source of electrical interference.
- Do not bend the cable to a radius less than 30mm as this may shorten its life.
- Do not use a fixing method that may cut, damage or excessively crush the cable.

## 4. Operating the Sonar

To summarise, your system should be connected in a similar configuration to the figure shown below, and once you've installed sonar transducer on the hull (or other suitable mounting bracket) as described previously, you're ready to run the "Scanline" software, and start collecting data...

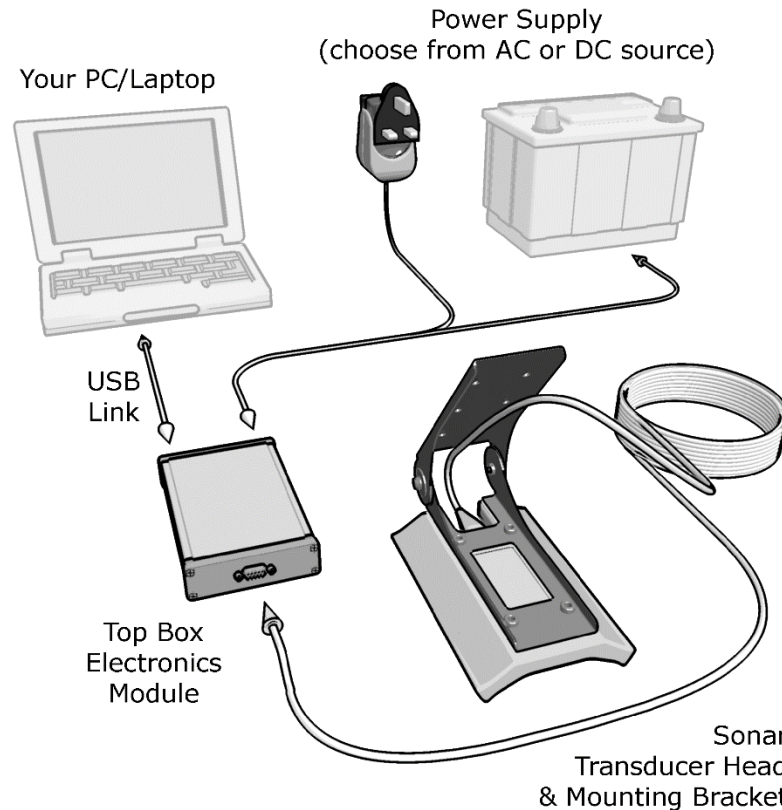

Refer to the separate "Scanline User Guide" for information on installing, starting and operating the software.

Operating the sonar is relatively straightforward, but there are a few guidelines and precautions you should observe to achieve the best results...



- Keep the boat speed constant, and ideally between 1 and 4 knots for the best results. At slower speeds more display lines will be acquired for smaller targets (giving a higher resolution image).
- Be aware of hazards to navigation and the sonar transducer. The sonar transducer head will only show you the depth of the seabed below it, not from the surface, and not in front of it. So, if you are scanning in close proximity to the seabed, you should be keeping a close eye on the sonar display.
- If in doubt of the underwater terrain or possible hazards, always assume the worst case, and give plenty of clearance between the sonar transducer and the seabed.



**Please be aware that you should not rely on the sonar as a primary navigational aid for your vessel, or for avoiding shallows, submerged or mid-water hazards.**



When the "Scanline" software is running, the "Activity Indicator" will flash to show that the StarFish is scanning and acquiring data.



See the following section on interpreting side-scan imagery, for further details on calculating the sonar's altitude from the displayed data.

## 5. Understanding Sidescan Imagery

Interpreting side-scan imagery may seem difficult at first, but with practice and some knowledge of how the sonar works, it doesn't take very long for an operator to understand what the seafloor is doing below the sonar, and if there are any targets on it.

Many people try to look at the pictures and understand them as you would a photograph, but this however is not strictly the case. In the following sections, we will look at several example images, and see how information can be obtained from them.

### 5.1. What Is A Side-Scan Sonar?

Sonar (**SO**und **N**avigation **A**nd **R**anging) and echo-sounding technology dates back to the 1920's, but it was only in the early 1960's that Dr. Harold Edgerton (an electrical engineering professor at the Massachusetts Institute of Technology) started to adapt his techniques on high-speed flash photography to acoustics, having concluded that photography was not best suited to the murky conditions underwater.

By sending "flashes" of acoustic energy into the water and recording the echoes, Edgerton (who later worked with underwater explorer Jacques Cousteau), developed a towed side-looking sonar that could create a continuous image of the seafloor.

By transmitting a narrow fan-shaped acoustic pulse (ping) perpendicular to its direction of travel, the side-scan sonar sends acoustic pulses outwards. The seabed and other objects reflect some of the sound energy back in the direction of the sonar (known as backscatter), and the travel time of the returned pulse is recorded together with its intensity.



As sound travels at a known velocity (of approximately 1500 metres per second) through water, we can directly relate the time we received an echo, to the range of the target that reflected it.

This scan-line of information is sent to a topside computer for interpretation and display, and by stitching together data from successive pulses, a long continuous image of the seafloor is created as the sonar is moved by the survey vessel.

As mentioned previously, your StarFish has two transducers (transmitter and receiver elements) that are angled 30° down from the horizontal, and acoustically transmit sound in a "fan beam" of narrow width (refer to the specification of your StarFish product for the exact width), but wide vertically with most of the acoustic energy confined to the centre 60° of the beam.

This gives the StarFish the ability to see almost directly below it, to just above the horizontal.

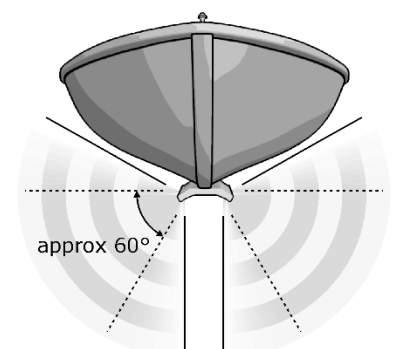

However, despite this field of vision, the StarFish cannot determine where a target lies vertically in its beam (i.e. above or below it), as everything is translated to a planar 2D display.

For example, if there are two targets both 10 metres from the sonar (one horizontally level with it, and one directly below it, and are received on the same channel) they would both appear at the same point on the sonar display, as the display scale is based around time, and both echoes would arrive simultaneously.

With some experience though, image artefacts like "acoustic shadows" can help the operator make an educated guess to the size of targets and sea-bed features.

## 5.2. What Does A Side-Scan Sonar Image Look Like?

The figure below is a real image captured by a StarFish sonar, where each horizontal line is a representation of time versus the intensity of the reflected echoes. The further something is away from the centre line of the display, means the longer it took for the echo to be received.

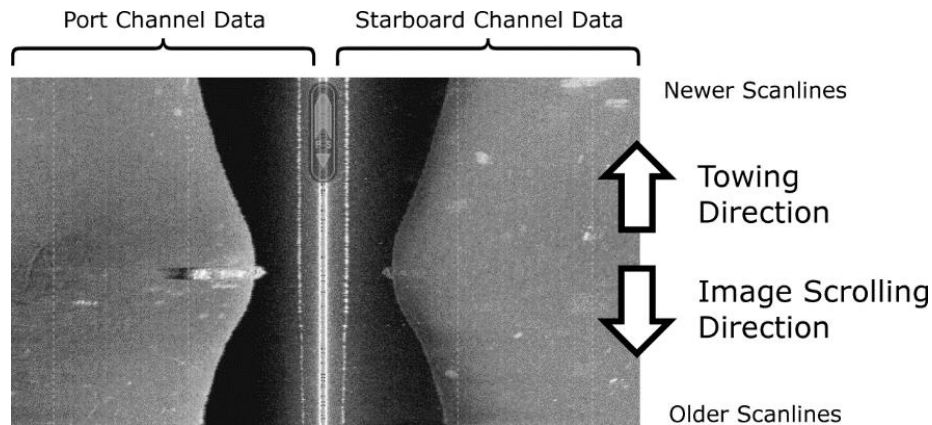

In this figure, both the port (left) and starboard (right) channels are operating at the same time. The sonar is positioned in the middle of the topmost line, and as the sonar is moved through the water the image will scroll away from it as more data is added.

## 5.3. Calculating Depth Below The Sonar (Altitude)

A useful measure to know when using a side-scan sonar is the height above the seafloor, so a safe distance can be maintained and hazards avoided.

Looking at the previous image, we can see a large black “hour-glass” shaped area in the middle of the display, where no echoes have been received.

This area is showing us the height the sonar is above the sea bed.

As the figure opposite shows, the nearest object to the sonar will always be the seabed below it (assuming a relatively flat seabed).

However, it will take some time for the “bottom echo” to be returned, and as the display shows the received echoes from when the transmission started, this area appears black.

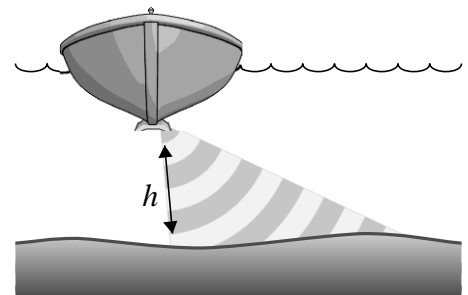

Therefore, the narrower the band of black is, the closer the sonar is to the seabed – and as the image is built up over time, if the sonar’s altitude changes we start to see the profile of the seabed that the sonar has passed over.

This means in the figure above, the seabed gets shallower in the middle of the display, and then gets deeper again at the bottom.

## 5.4. Calculating The Distance To A Target

As mentioned earlier, the sonar display shows the recorded echoes over a period of time, and we have seen how we can work out the depth below the sonar from this.

However, this also means that the range a target appears to be on the display is not the distance it lies at from the sonar horizontally across the seabed.

To understand why this is the case, consider the triangle shown in the figure opposite.

As the sound waves travel from the sonar, they start to hit the seabed, and each point of contact returns an echo along the shortest path to the sonar.

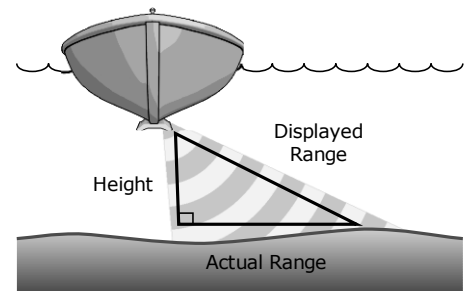

To work out the actual distance at which a target lies, you need to use the mathematical formula (based on Pythagoras's theorem) ...

$$\text{Actual Range} = \sqrt{\text{DisplayedRange}^2 - \text{Height}^2}$$

## 5.5. Acoustic Shadows

When sound from the sonar hits a submerged target with any height above the seabed, an acoustic shadow will be cast away from the sonar.

An experienced sonar operator can use the lengths of these shadows, along with knowledge of the sonar altitude to get an idea of the size and height of the object.

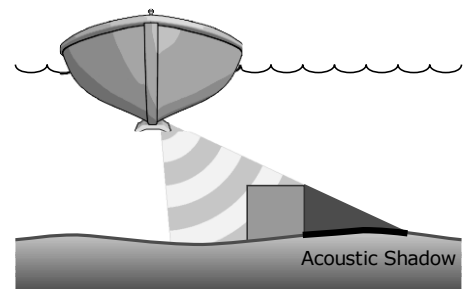

To help understand this, imagine you are in a darkened room, with a flashlight, standing above a ball. If you shine the flashlight down on the ball, a small shadow is cast around it, while if you lie down level with the ball and shine the light at it, a much longer shadow is produced stretching away from it.

This principle applies to side-scan sonar in a similar way; objects directly beneath the sonar will appear to have very small shadows, while objects at greater distances will have longer shadows because they are being illuminated (acoustically) on their side.

## 5.6. Reflected Target Intensity

To complete our understanding of the basics of sonar imagery, we need to consider the brightness information (intensity of echo) shown on the sonar display.



As with a surface reflecting light, different surface textures and materials of targets have different acoustic reflective properties.

Typically, the more the density of the target differs from that of water, or the more rigid its material is, the more sound is reflected back.

- Any target with a gas in (such as air) will act as an almost perfect reflector for sound, and will show as the brightest colour in the palette.
- Muddy or silted lake and sea beds will generally show up as a low-intensity background colour, as mud is a good sound absorber and contains water.

The example image below shows several bright targets of interest...

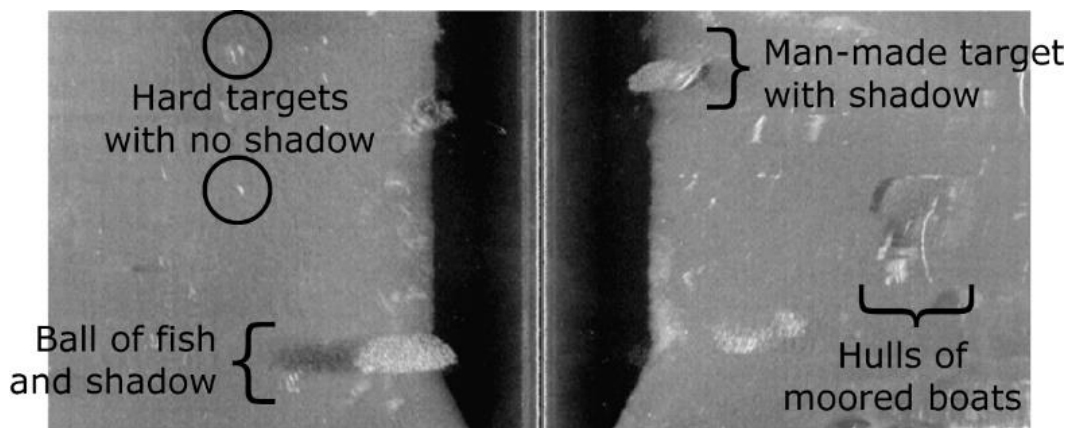

Taking what we already know about sonar imagery into account we can interpret the following...

- White 'dots', without any form of shadow are most likely either flat hard targets on the bottom or large mid-water fish (with their air-filled swim-bladder showing up on the sonar).
- At the bottom of the image we can see a bait-ball of fish – identifiable as large spherical structure that protrudes above the seabed profile (there is a faint and fragmented shadow extending away from it, implying it is not a single solid target).
- On the right of the image, we can see several vertical curved white lines. These are most likely the hulls of moored boats, and close to them we can see the square outlines of the concrete mooring blocks.
- At the top of the image, there is a large target. As it appears on both channels, and we can see its profile, we know the sonar has passed directly over it. The bright geometric echoes on it indicate it is probably man-made, and there is an acoustic shadow visible on the right portion of it, showing it has height. It is most likely this is the wreck of a sunken vessel.

## 5.7. Example Side-Scan Sonar Images

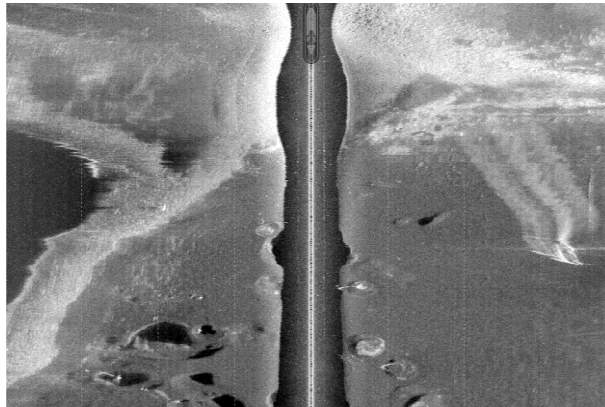

### Lake Bed

Scan showing boat moorings at the bottom (concrete blocks in craters of silt).

The dark area on the left channel is the shoreline. A boat with wake is visible on the right.

At the top of the right channel, it can be seen that the bottom has a rockier texture, and appears brighter than the silt in the rest of the image.

### Cable Car Ferry

Lake bed beneath a cable-hauled car ferry. The two cables are visible above the bottom, crossing beneath the sonar.

The movement of the cables has exposed the bedrock of the lake, causing a brighter reflection.

The grooves are visible on the centre profile on the lakebed, and the shore and slip-way are visible in the top left.

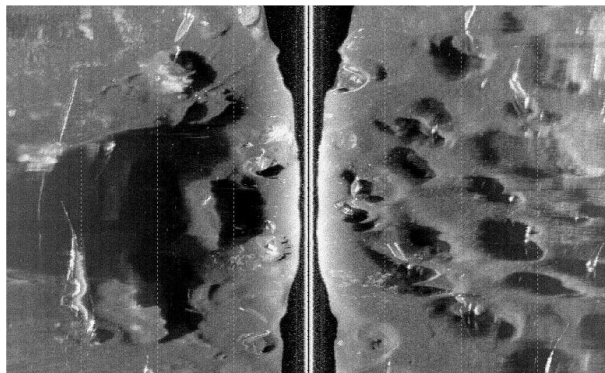
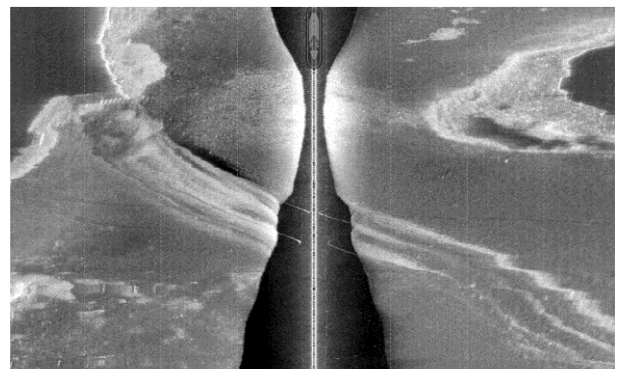

### Marina

Shallow water with moored boats. The bright white targets of the hulls are visible, above “craters” in the silt, caused by the movement of the mooring cables.

Note the large acoustic shadow on the left channel, caused by a raised area of the seabed being almost level with the sonar in the shallow water.

### Coral Reef

Horizontal image orientation showing a scan over coral reefs.

At the extreme right of this image, ripples in the sand are visible, while each coral outcrop has clearly visible shadows.

Note how close the sonar came to a small outcrop at the centre of the image!

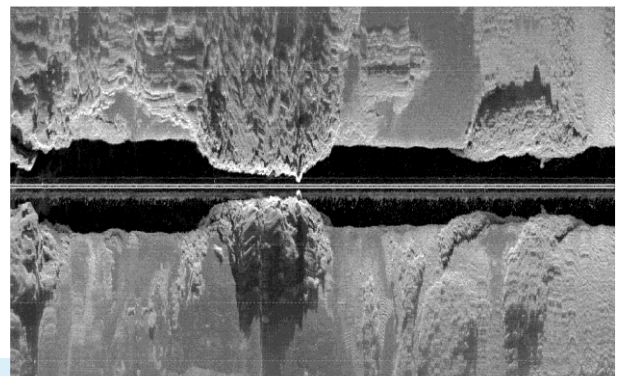

## 5.8. Gain & Contrast Settings

When operating your sonar, the adjustments you will make to the gain and contrast controls are critical in achieving good side-scan imagery. This section examines the function and purpose of these controls...



### Gain

The software gain control is similar to the volume control on a home hi-fi system, or the brightness control on a television.

The gain control sets how the incoming scan-lines of data (from the sonar hardware) map onto the display's colour palette.

- Increasing the gain value will make all areas of the display image appear brighter, while decreasing it will make the whole image appear darker.
- For general operation, a gain value of 30% (-28dB) is recommended.



### Contrast

The function of the contrast control is slightly more complex to understand than that of the gain control.

The contrast value sets the palette range that the incoming signal will be stretched or shrunk to fit.

- A lower contrast value means that the image will transition from dark to bright colours more quickly than a higher contrast value.
- For general operation, a contrast value of 30% (38dB) is recommended, but can be reduced to 25% to enhance shadows and submerged targets.

The best way to understand the operation of the Gain and Contrast controls is to experiment with these values while scanning the sonar over a known area of seabed.

Generally, having set the operational range of the sonar, you should then set the gain to a level where the background noise is just visible. This should ensure that quiet signals are visible at the extremities of the display, whilst the central mid-water areas and seabed profile have good definition.

Then, when scanning, adjust the contrast to give the desired sharpness of targets – lowering the contrast will make echoes appear brighter, while keeping shadows dark.

## 5.9. Shallow Water & Channels

When operating in shallow water and channels, you may experience a “ghosting” effect caused by acoustic returns from previous sonar “pings” still bouncing between targets and the sonar receivers.

To reduce these effects, use a larger “range” on the sonar display, which should have the effect of slowing the “ping rate” and allowing time for these echoes to dissipate.



In shallow water, you may also see distortion on long range targets, caused by “multi-path” phenomenon – where sound is reflected between the seabed and surface before hitting the target.

Due to surface waves and chop, the effect can manifest its self as ripples on distant targets.

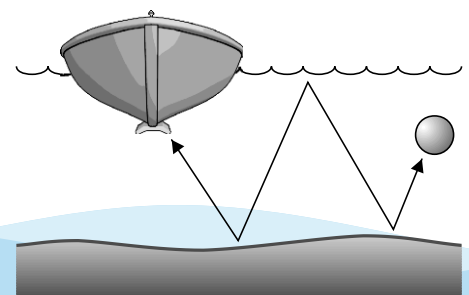



## 5.10. Tips For Good Imagery

### Vessel Speed

When using the StarFish, remember that it is “pinging” at a fixed rate (depending on range). The faster you move the sonar through the water the more compressed images will appear on the display.

For long ranges, try to travel at speeds between 1 and 3 knots, while shorter ranges can be used with speeds of 3 to 6 knots.

### Water Depth

The depth of water beneath the sonar is an important factor to consider when interpreting heights of submerged objects from their acoustic shadows. In shallow water acoustic shadows from targets appear very elongated (like shadows cast from objects at sunset), while in deep water the seabed will appear more as a “birds-eye” type view with minimal shadows.

### Mounting Position

The position and method of mounting the transducers on the hull is probably one of the biggest factors in determining overall image quality. As discussed in previous sections, the transmitter and receiver faces on the transducer should...

- Have no obstructions in their acoustic beams that may cause shadows or reflections.
- Be clear of any turbulence or cavitation from the hull in front of them.
- Be clear of turbulence or aeration caused by the vessels propeller.

### Boat Navigation

When surveying an area, think about the course you will steer your vessel over. Try to divide the area into a grid of long straight runs, with 180° turns at the end.

Remember that as the boat turns, the acoustic beams from the inside of the turn will overlap, while the outside ones will be covering more seabed – consequently the imagery produced will appear distorted and hard to interpret in these areas.

Give plenty of clearance between your boat and other vessels or surface/mid-water hazards, and try and avoid the aerated water left in the wake of other boats, as this will be acoustically visible for some time should you cross through it with your sonar.

### Waves, Wake and Surface Chop

As your StarFish is operating close to the surface, its imagery may be distorted by the motion of the boat due to waves and surface chop on the water, or it may receive reflections from these at longer ranges.

Consequently, your StarFish will not perform well in rough stormy conditions.



**Remember, that when in a boat, your own safety is paramount and should not be compromised trying to achieve good sonar imagery.**

## 6. Safety



### 6.1. Electrical Safety

The AC power adaptor and surface control box are **NOT** protected against the ingress of water, so take care to avoid exposing the unit to sources of conductive liquids. Dry wet hands before handling the AC power adaptor or surface control box.

- Do not attempt to disassemble or service this product yourself (outside the scope described in this manual). Contact StarFish technical support for any maintenance, spares or repair work required.
- Do not overload a mains supply outlet, extension cord or adapter as this may result in electric fire or shock.
- Do not modify the power cord or plug.
- Do not place the AC adaptor or power cord near any heat sources that may melt the protective insulation.
- Do not use this product if any of the cabling, or housings of its component parts appear to be damaged or compromised for the ingress of water.
- Do not use (and ensure the product is unplugged) in situations where a power-line surge may occur (such as a lightning storm), or if the product is not used for a prolonged period of time.
- Ensure that the power supply has suitable earthing, and electrical shock risk is minimised through the use of fusing and residual-current-detection (RCD) devices.



### 6.2. Operational Safety

- Do not rely on the product to necessarily represent the immediate sub-surface conditions below the boat, and as such this product should not be used as a direct means of avoiding submerged objects, shallow water & grounding, collisions with other vessels, boat damage or personal injury. If you are in doubt about any of these hazards, always operate your boat and sonar at reduced speeds, and proceed with caution.
- Do not rely on this product as a navigational aid.
- Do not allow the sonar transducer cable to obstruct or present a hazard to other personnel on the deck area or passage-ways of the boat. Use the provided cable-tie to coil and secure any surplus cable.
- Do not rely on the connection between the electronics box and the transducer cable, as a means of securing the sonar to the boat. The sonar transducer head should be fixed directly to the boat hull.

### 6.3. Other Precautions



For storage and maintenance information, please refer to the section “Maintenance & Cleaning” (see page 19).

If you have any other safety or operational queries, please contact StarFish technical support (see page 21).

## 7. Care Of Your Starfish

### 7.1. Operational Care



In addition to the points highlighted in the “Safety” section (see page 18), please observe the additional precautions...

- Do not operate the product near a source of heat that may cause the operational temperature parameters to be exceeded (see specifications on page 24), or stack other heat generating equipment on top of the unit.
- Always use the electronics module on a stable, non-slip, rigid, flat and lint-free surface.
- Make sure the product is more than 10cm away from any other appliance that may be susceptible to electromagnetic interference.

### 7.2. Maintenance & Cleaning



When you have finished using your StarFish sonar, you should...

- Disconnect the product from the power supply before attempting any maintenance or cleaning.
- Remove any weed, or other detritus, from the sonar head and cable, that may have been collected during its operation.
- Wipe, with a damp cloth, any salt-water spray that may have inadvertently settled on the surface of the “top box” electronics module and connectors.

Additionally, please observe the following precautions for cleaning and maintenance...

- Do not clean with solvents, and only use a damp cloth on the exterior of the unit.
- Do not undertake maintenance of the unit, outside the scope of that defined within this manual, unless instructed to do so by Technical Support.
- Do not insert extraneous object (metal or other alien substance) into the unit or any of its connector apertures.

### 7.3. Storage



When storing or shipping the StarFish system, please observe the following...

- Avoid excessively bending or kinking the cable (below a radius of 30mm), as this could reduce its operational life.
- Avoid excessive and large fluctuations in temperature.
- To prevent corrosion, remove any salt or other residues from the product before storage out of the water.
- Store in a well-ventilated enclosure after use, to allow any moisture on system components to evaporate naturally.
- Ensure no point-load is exerted on the transducers on either side of the sonar transducer head.

## 8. Troubleshooting



Below is a table of common problems and solutions, but if you have a problem that cannot be solved from the table below, or an issue that is not covered, please contact Technical Support - see page 21 for further details.

**Note:** For software issues and problems, please refer to the accompanying “Scanline User Guide”.

<i>Problem...</i>	<i>Solution(s)...</i>
<b>Electrical interference</b>	<p>This is most commonly seen as bright small snow-like dots over the image – usually with some form of regular repeating pattern.</p> <p>The most common cause is interference from other high-current switching electrical devices (such as mains inverters, or motors) connected to the same power source as the top box electronics module.</p> <p>Try methodically turning off other electrical devices to find the cause, or running the StarFish from its own dedicated supply (or battery).</p>
<b>Acoustic noise</b>	<p>This is most commonly seen as large stripes or pulses of varying brightness over the image, usually with some form of regular repeating pattern.</p> <p>Try to identify and, where possible, remove the source of the acoustic noise. Most commonly, your boat, or other vessels, may have an echosounder that is running at a frequency close to the operating frequency band of the StarFish.</p>
<b>Image ghosting or mirroring</b>	<p>This problem may occur if the StarFish is operating in close proximity to the boat hull. If depth permits, try deploying more cable to distance the sonar transducer head from the boat.</p> <p>This problem can also occur in shallow water, where the high-intensity transmission from one transducer is being received by the other. If possible, use the software to display only a single channel (and prevent transmissions from the other); this will reduce the inter-channel cross-talk.</p>

## 9. Product Support

### Website

For the latest software and firmware updates, as well as production information, manuals and datasheets, visit

[www.blueprintsubsea.com/starfish](http://www.blueprintsubsea.com/starfish)

We welcome any feedback you may have about the StarFish system, from bug reports to ideas for new features or hardware to support – please use the contact details on the website (or shown below) to get in touch.

### Technical Support

If your StarFish system is not operating properly, please consult the ‘Troubleshooting’ section of this manual and further information on the Blueprint website to see if the problem can be easily remedied.

However, if you need further support, you can contact us via your distributor or directly at...

- Web [www.blueprintsubsea.com/starfish](http://www.blueprintsubsea.com/starfish)  
(for access to on-line resources and technical support)
- Email [enquiries@blueprintsubsea.com](mailto:enquiries@blueprintsubsea.com)
- Telephone +44 (0)1539 531536  
(9:00am to 5:00pm, Monday to Friday, UK Time)

For all the above please provide the following information to help us with your technical support request...

- Part and Serial Numbers of the system components. These are located on the labels of each item, and are in the form “BPxxxxx.xxxxxx”.
- Version number of the Scanline software and firmware you are using.
- The operating system name, version, type (32 bit or 64 bit) and service pack upgrade your computer is using.
- Brand and model of your computer (processor type and memory configuration are also useful if known).
- Name of the distributor where the system was purchased from.



If you need to return your StarFish system for servicing, please...

- Contact us (using the details above) for returns information and shipping details.
- Pack your StarFish system back in the original packaging (or other suitable container), and include written documentation including your contact details (including contact phone number), a description of the problem and any symptoms occurring.
- If your product is still under warranty, please include a copy of your receipt (showing proof and date of purchase).
- Please return the product back to Blueprint Subsea, using an insured courier and delivery confirmation.

## 10. Limited Warranty Policy

The manufacturer, Blueprint Design Engineering Limited (trading as Blueprint Subsea and hereafter after referred to as Blueprint), warrants that at the time of shipment all products shall be free from defects in material and workmanship and suitable for the purpose specified in the product literature.

### Conditions

Unless other terms are specifically requested and mutually agreed in writing prior to dispatch, the conditions of the warranty include, but are not limited to:

- The warranty is only deemed to be valid if the equipment was sold through Blueprint or one of its approved distributors.
- The warranty commences immediately from the date of customer acceptance and runs for a period of 365 days. Customer acceptance will always be deemed to have occurred within 72 hours of delivery.
- The equipment must have been installed and commissioned in strict accordance with approved technical standards and specifications and for the purpose that the system was designed.
- The warranty is not transferable.
- Blueprint must be notified immediately (in writing) of any suspected defect and if advised by Blueprint, the equipment subject to the defect shall be returned by the customer to Blueprint, via a suitable mode of transportation and shall be freight paid.
- The warranty does not apply to defects that have been caused by failure to follow the recommended installation or maintenance procedures, or defects resulting from normal wear & tear, incorrect operation, fire, water ingress, lightning damage or fluctuations in vehicles supply voltages, or from any other circumstances that may arise after delivery that is out with the control of Blueprint. (Note: The warranty does not apply in the event where a defect has been caused by isolation incompatibilities.)
- The warranty does not cover the transportation of personnel and per diem allowances relating to any repair or replacement.
- The warranty does not cover any direct, indirect, punitive, special consequential damages or any damages whatsoever arising out of or connected with misuse of this product.
- Any equipment or parts returned under warranty provisions will be returned to the customer freight prepaid by Blueprint
- The warranty shall become invalid if the customer attempts to repair or modify the equipment without appropriate written authority being first received from Blueprint.
- Blueprint retains the sole right to accept or reject any warranty claim.
- Each product is carefully examined and checked before it is shipped. It should therefore be visually and operationally checked as soon as it is received. If it is damaged in anyway, a claim should be filed with the courier and Blueprint notified of the damage.
- Any customer acceptance testing (if applicable) must be performed at either Blueprint premises or at one of their approved distributors unless mutually agreed in writing prior to despatch.

Blueprint reserve the right to change specifications at any time without notice and without any obligation to incorporate new features in instruments previously sold.

If the system is not covered by warranty, or if it is determined that the fault is caused by misuse, repair will be billed to the customer, and an estimate submitted for customer approval before the commencement of repairs.

## 11. Notices

### Copyright

Blueprint Subsea is a trading name of Blueprint Design Engineering Ltd. Copyright © 2017 Blueprint Design Engineering Limited, all rights reserved.

No part of this publication may be reproduced, stored in a retrieval system, or transmitted in any form or by means (electronic, mechanical, photocopying, recording or otherwise), without the prior written permission of Blueprint Design Engineering Ltd.

### Disclaimer

Neither Blueprint Design Engineering Limited, or their affiliates shall be liable to the purchaser of this product, or third parties, for losses, costs, damages or expenses incurred by the purchaser or third parties as a result of accident, misuse, abuse, modification of this product or a failure to strictly comply with the operating and maintenance instructions.

### Trademarks

The Windows™ operating system is a trademark of the Microsoft Corporation. Other product and brand names used within this document are for identification purposes only. Blueprint Design Engineering Ltd. disclaims any and all rights in those marks.

### Third-Party Software Applications

Third-party applications referred to in this document (such as Google Earth and Microsoft Windows) are not affiliated with Blueprint Design Engineering Ltd. in any way, and the content provided here is on an “as is” basis for information only. Blueprint Design Engineering Ltd. can offer no technical support for these applications (unless stated otherwise in the text), or accept responsibility whatsoever for any damages arising out of the use of information contained in the documentation by other parties, and makes no guarantees, expressed or implied, about its availability, quality, reliability, functionality or any other characteristic.

### Specifications & Content

All information in this document is believed to be correct at the time of going to press, Blueprint Design Engineering Ltd cannot be held responsible for any inaccuracies or omissions. If you find an error or feel we have missed important or useful information, please contact us. The latest version of the manual is always available to download from the website.

Specifications and information contained in this document are subject to change without notice, and does not represent a commitment on the part of Blueprint Design Engineering Ltd.

### Handling Recommendations



The StarFish system contains sensitive electronic components that may be damaged by an Electrostatic Discharge (ESD) if handled incorrectly. To minimise risk of damage, users should avoid dismantling the unit, touching any exposed electrical contacts on external connector, or inserting anything other than the recommended cabling into the connectors.

### Waste Electrical & Electronic Equipment Statement



Under the European Union (EU) directive on 'Waste Electrical & Electronic Equipment' (Directive 2002/96/EC), from August 13, 2005, products categorised as electrical or electronic equipment cannot be discarded as municipal waste by placing in landfill, dumping in the sea or incineration. SEPARATE collection is mandatory.

At the end of its life, you should either return this system and its associated leads & accessories (if appropriate) to Blueprint Design Engineering Ltd with a certificate of decontamination (we reserve the right to protect our staff from the effects of any contamination) or it should be sent to an appropriate treatment or recycling agency.

### Restriction of Hazardous Substances Statement



Under the European Union (EU) directive on the 'Restriction of Hazardous Substances' (Directive 2002/95/EC), from July 1, 2006, electrical and electronic equipment cannot contain lead ("lead free"), mercury, cadmium, hexavalent chromium, polybrominated biphenyls (PBB) or polybrominated diphenyl ethers (PBDE).

All components of the StarFish system, sold by Blueprint Design Engineering Ltd, fully comply with this legislation where applicable.

## 12. Specifications

### Transducer

Part Number	StarFish 450H (5m) BP00082	StarFish 450H (20m) BP00092
Frequency	450kHz CHIRP	
Operating Range	100m (328ft) per channel	
Horizontal Beam Width	1.7°	
Vertical Beam Width	60°	
Transducer Angle	Tilted Down 30° from Horizontal	
Length	195mm (7.68")	
Width	130mm (5.12")	
Height	35mm (1.38")	
Weight (in Air)	0.7kg (1.54lb)	
Construction	Reinforced polyurethane rubber	
Colour	Black	
Depth Rating	50m (164ft)	
Inline Connector	N/A	

### Cable

	5m (16ft)	20m (65ft)
Length	5m (16ft)	20m (65ft)
Construction	Black polyurethane jacket with internal Kevlar reinforcing (strain) member	
Breaking Strain	>150kg (330lb)	
Minimum Bend Radius	30mm (1.2")	

### Top Box Electronics Module

Part Number	450 Series BP00019
Supply Voltage	90-264VAC, 47-63Hz or 9-28VDC
Power Consumption	6W (500mA @ 12VDC)
Power Interface	2.1mm DC jack socket
PC Interface	USB 2.0 B-Type connector
Length	166mm (6.54")
Width	106mm (4.17")
Height	34mm (1.34")
Weight (in Air)	0.4kg (0.88lb)
Temp Range	-5°C to +40°C (23°F to 104°F)
IP Rating	IP50 (Protection against ingress of dust, no protection against ingress of liquids)

*Note, all data given above may be subject to change at any time.*



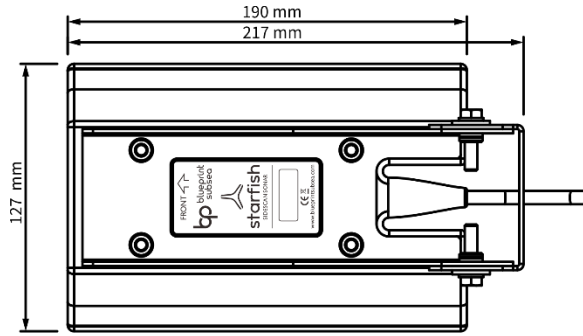

TOP ELEVATION

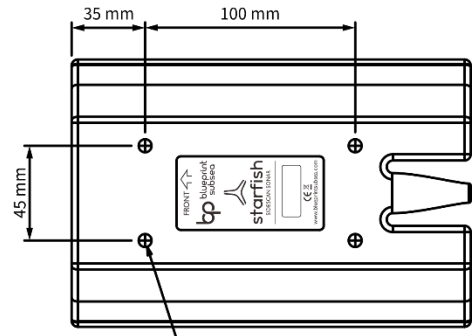

TOP ELEVATION WITHOUT BRACKET

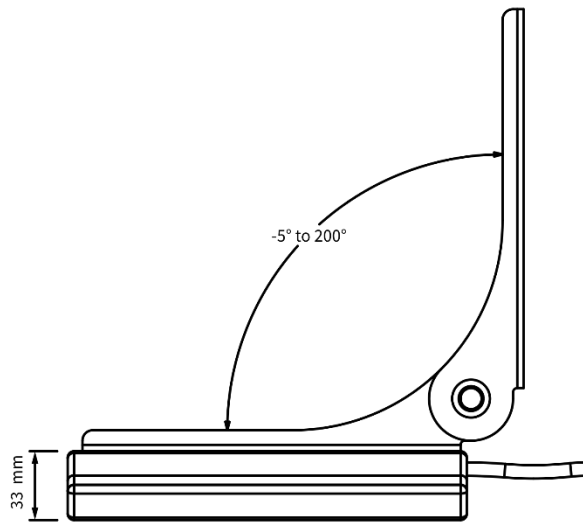

SIDE ELEVATION

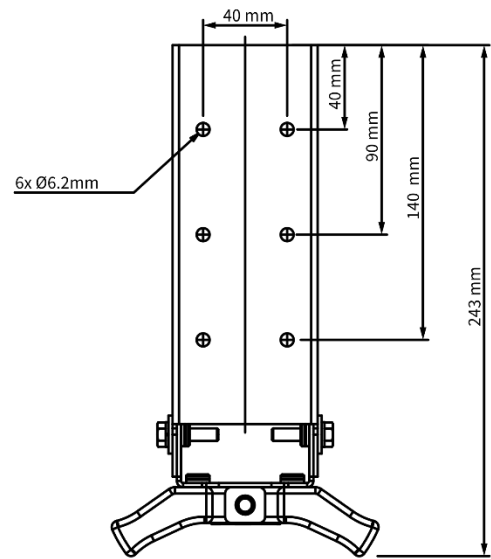

FRONT ELEVATION



BACK ELEVATION

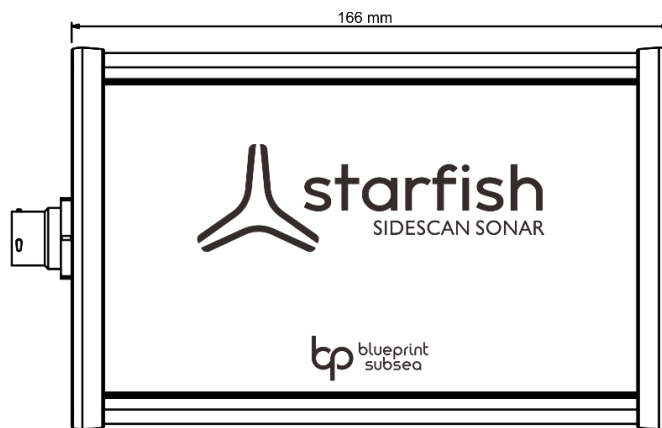

TOP ELEVATION

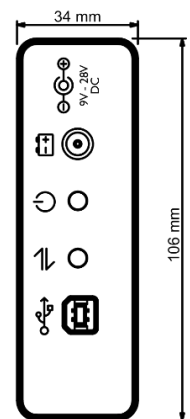

FRONT ELEVATION

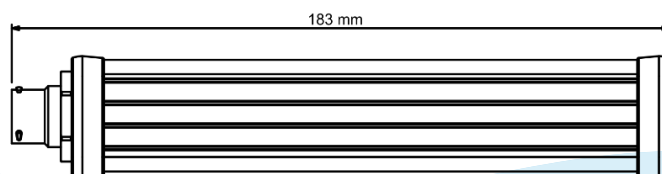

SIDE ELEVATION



## 13. Index

### A

AC Power, 5  
Activity Indicator, 10  
Aeration. *See* Cavitation  
Altitude, 12

### B

Beam Angles, 7, 11

### C

Cable, 9  
Cavitation, 8, 17  
Chop. *See* Waves  
Cleaning, 19  
Connections, 6  
Contrast, 16  
Corrosion, 19  
Custom Power Leads, 5

### D

DC Power, 5  
Density (of targets), 14  
Depth, 17

### E

Electrical Noise, 5

Electrical Safety, 5, 18, 19, 20

Example Images, 15

External Fuse, 5

### G

Gain, 16

Ghosting, 7, 16

### H

Hazards, 8, 10

Height, 12

### M

Maintenance, 18, 19

Mounting Position, 7, 9, 17

### N

Navigation, 10, 17

Noise, 8

### O

Operational Care, 19

Operational Safety, 18

### P

Ping, 11

Power Consumption, 5

Power Supply, 5

Power/Status Indicator, 6

### R

Range, 13

Recycling, 23

### S

Safety, 3, 18

Shadows, 7, 13

Shallow Water, 16

Software, 6

Sonar, 11

Speed, 10, 17

Storage, 19, 20

### T

Target Distance, 13

Target Intensity, 14

Technical Support, 21

Transducers, 7, 8, 9, 11

Troubleshooting, 20

Turbulence, 8, 17

### W

Warranty, 22

Waves, 16, 17



Distributor...